

# SEM OPTIONS



Let's get  
**Sirius**  
with rangehood design

## *External Motors*—OUTSIDE THE HOUSE



### SEM7 EXTERNAL

- Motor: 2300 m<sup>3</sup>/h extraction
- Aluminium die-cast motor housing
- Absorption: 265W
- Pressure: 480 Pa
- Noise level 68 dBA
- **Ducting 200mm**

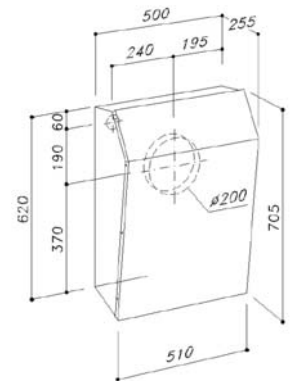

## *Internal Motors*—INSIDE THE HOUSE



### SEM8 INTERNAL

- Motor: 1650 m<sup>3</sup>/h extraction
- Aluminium die-cast motor housing
- Absorption: 265W
- Pressure: 480 Pa
- Noise level 65 dBA
- **Ducting 200mm**

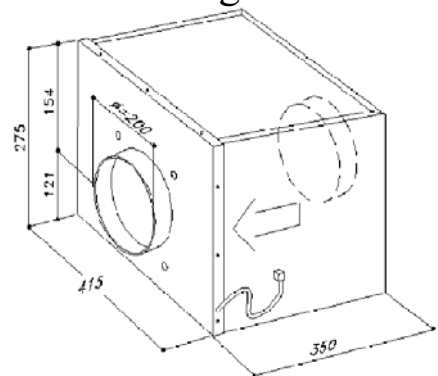

# SEM OPTIONS



let's get  
**Sirius**  
with rangehood design

## *External Motors*—OUTSIDE THE HOUSE

### Technical Specifications:

MODEL	SEM 7
MOTOR	German Made
EXTRACTION	2300 m <sup>3</sup> /h extraction
DUCTING DIAMETER	Ducting 200mm
NOISE	68dBa
PRODUCT DIMENSIONS	W - 510mm x H - 705mm x D - 255mm

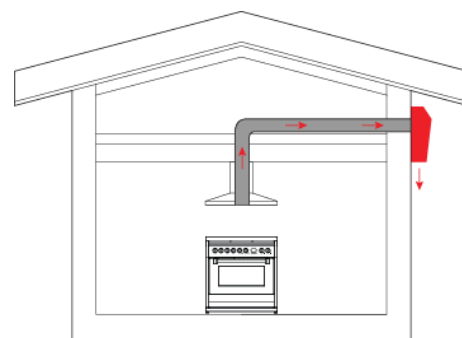

Canopy Installation

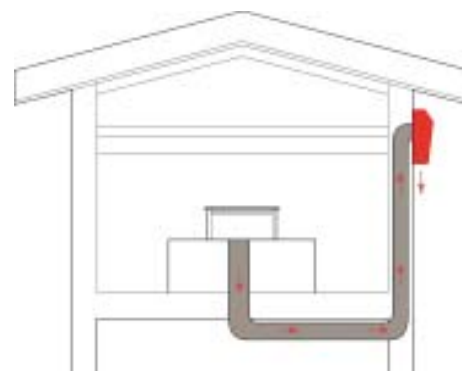

Downdraft Installation

## *Internal Motors*—INSIDE THE HOUSE

### Technical Specifications:

MODEL	SEM 8
MOTOR	German Made
EXTRACTION	1650 m <sup>3</sup> /h extraction
DUCTING DIAMETER	Ducting 200mm
NOISE	65dBa
PRODUCT DIMENSIONS	W - 350mm x H - 275mm x D 415mm

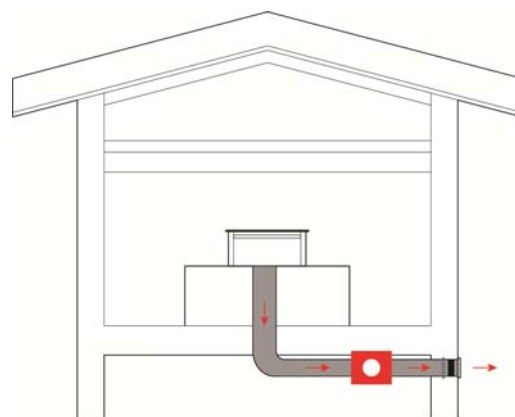

Downdraft  
Install

Distributed by Arisit Pty Ltd

40-44 Mark Anthony Drive, Dandenong South VIC 3175 Ph: 1300 762 219 Fax: 03 9768 0838 Website: [www.arisit.com](http://www.arisit.com)